

AUTOCLAVE

STEAM STERILIZATION



FULLY AUTOMATIC



AUTOCLAVE

ULTRA FAST CLASS S

12
minute
CYCLE

ULTRAFAST CLASS S

FULLY AUTOMATIC

CLAVE8+



12 Minute Cycle



Small Footprint



Big Power



Distilled Water

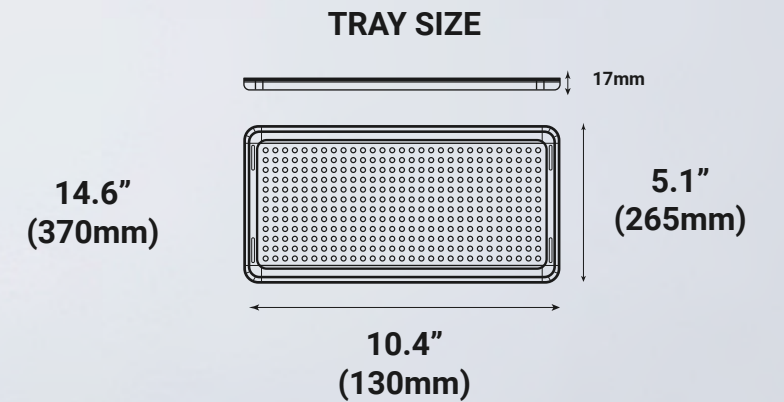
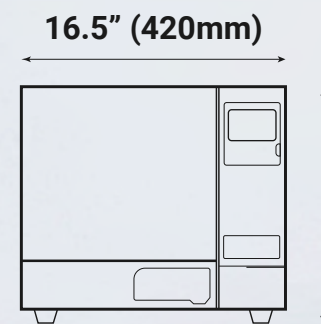
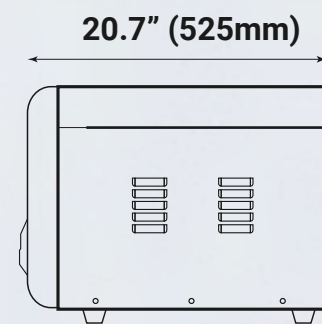

Standard Configuration
3 trays

USB Datalogger
& Internal Printer
Included

12 Minute Cycle

Small Footprint

Big Power

Distilled Water Tank



Stainless Steel Chamber



USB Port



LCD Screen



Water Filter

Waste
Water Drain

Distilled
Water Drain

CLAVE8+

THE FLIGHT CLAVE8+

Is a high-performing, compact Class S autoclave uniquely designed for fast, efficient, and reliable sterilization in diverse professional environments. Its advanced steam pulsing, air-assisted drying, and safety features make it a standout choice where both speed and safety matter.

Drying & Efficiency Upgrades

- Integrated compressor / vacuum system accelerates drying—cutting closed-door drying time from ~60 minutes to ~30 minutes.
- Air-assisted closed-door drying ensures instruments are fully dry and ready to use at the end of the cycle.
- 8L chamber (6.7"× 12.6") with three stainless-steel trays, delivering greater sterilizing capacity than single-cassette sterilizers while maintaining comparable cycle times.
- Independent steam generator, double-door protection system, USB port, and internal printer support both safety and documentation.

BEST FOR:

Excellent sterilizer for use in Dental offices, Veterinarian offices, Medical offices, Podiatry, Chiropractic, Tattoo and Beauty salons.



FULLY AUTOMATIC



AUTOCLAVE CLASS S

CLASS S

CLAVE16+

With compressor for drying

FULLY AUTOMATIC



CHAMBER TYPE

9 CHAMBERT

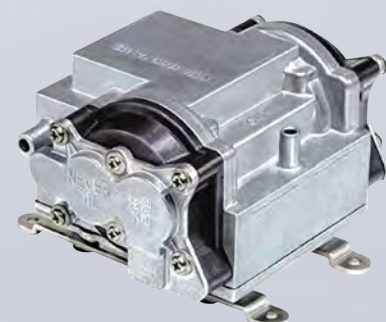

Built in compressor for
Faster Drying Times
30 Minutes Closed Door Drying

SAFETY

- The double-door protection system ensures safe operation by preventing the cycle from starting unless the door is securely locked. It also prevents the door from opening until the pressure inside the chamber has equalized with atmospheric pressure outside the chamber
- Pressure safety valve prevents over pressure in the chamber and steam generator.
- The power is automatically cut if a short circuit or electrical fault occurs.
- The system is able to detect any problems or faults with the machine using specific error codes making diagnosing and trouble shooting much easier and faster.
- A built-in water level sensor monitors minimum and maximum levels and alerts the user accordingly.

STERILIZATION PROGRAMS

Pre-Programmed Cycles Cover all common dental, medical and veterinary sterilization needs.

Programs	Temp °C	Pressure k.Pa	Type	Total time (Mins)
Unwrapped	134	210	Unwrapped solid material	14-30
	121	110		30-45
Wrapped	134	210	Wrapped solid or hollow material	30-45
	121	110		35-60
Liquid	134	210	Liquid	30-55
Plastic	121	110	Plastic	35-60
Prion	134	210	Unwrapped porous material	Total 30-55
			Single-wrapped porous material	
			Single-wrapped hollow material	
			Dual-wrapped solid & hollow material	

“

Compact in Size but Powerful and Fast Sterilization.
Suitable for all your Dental, Medical, Veterinary, Tattoo and
Beauty infection control needs



FEATURES

- Unique Pressure-Pulsing Steam Injection
- Intuitive and Easy to Use Touchpad
- Fast and Efficient Steam Sterilization
- Includes USB Port for Data management
- 5 Programmed Cycles
- 3 Tray Capacity (16L Capacity - 9" Chamber)
- High Quality 304 Stainless Steel
- Built-in Printer Included
- 2 Year Warranty

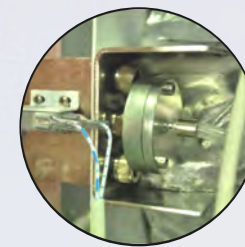

Double Locking
Mechanism



LCD Display



Printer port
and USB port

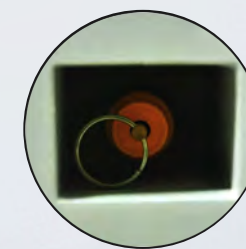

Pressure safety
valve



Electrical safety
breaker

LCD Display with Intuitive Controls

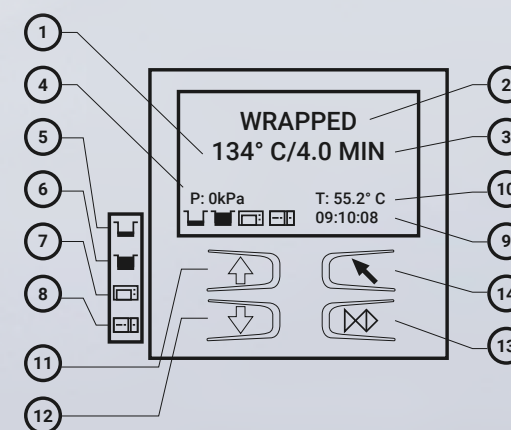
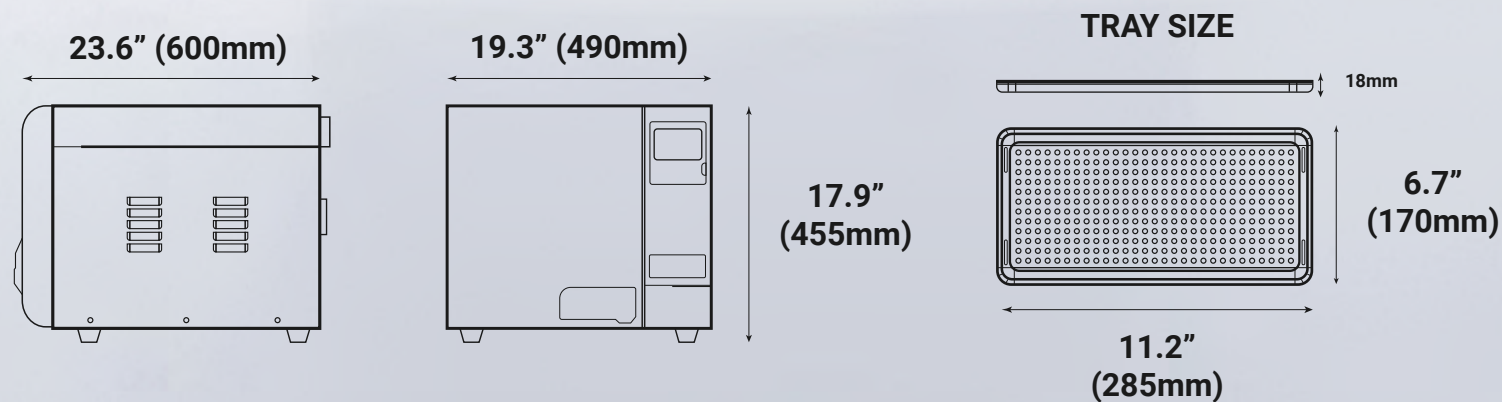

- 1 Program temperature
- 2 Program
- 3 Holding time
- 4 Pressure
- 5 Distilled water / Fill if flashing
 Filling the tank
 Bad water quality
- 6 Used water tank tabk full / Drain if flashing
- 7 Printer status
- 8 Door open
 Door closed
 Door blocked
- 9 Time
- 10 Current internal temperature
- 11 Up button
- 12 Down button
- 13 Enter button
- 14 Menu button



CLASS S

CLAVE23+



Simple and Effective Steam Sterilization that can help make processing instruments in the office fast and easy



FEATURES

- Unique Pressure - Pulsing Steam Injection
- Low Maintenance Autoclave Chamber Type
- Large Chamber Capacity 23L
- Can fit 4 Trays or 25 Instruments per Slot with Cassettes
- Includes USB Port for Data management
- 5 Programmed Cycles
- High Quality 304 Stainless Steel
- 2 Year Warranty

FULLY AUTOMATIC PROGRAMMED CYCLES

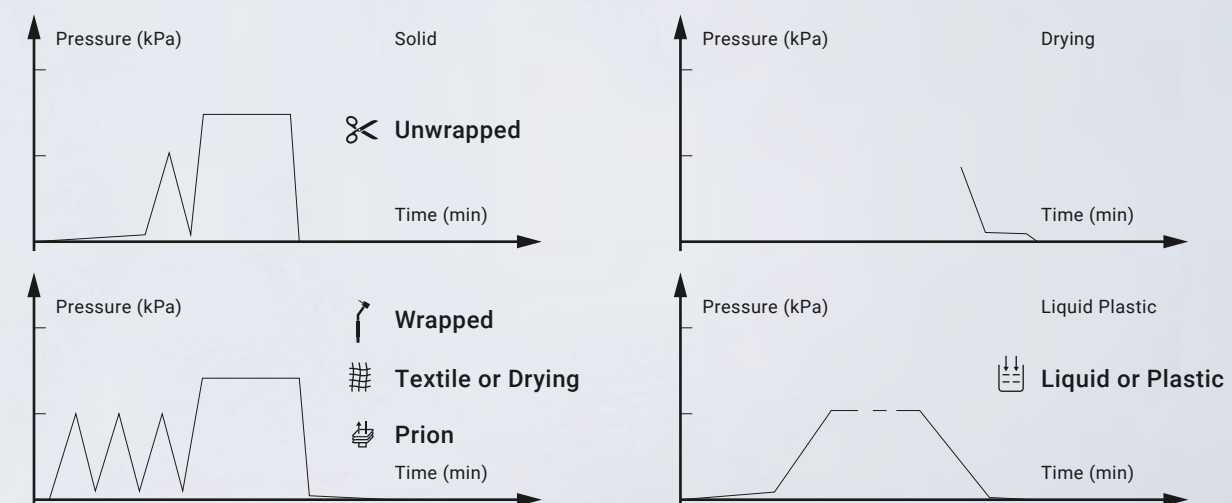

27.2" (690mm)

19.3" (490mm)

17.9" (455mm)

TRAY SIZE

18mm

7.6" (192mm)

15" (380mm)

Stainless steel chamber and trays

Touchpad control

Independent steam generator

Distilled water reservoir

DOCUMENTATION

Printer:

A Built in Printer is included with all models (Clave8+, Clave16+, Clave23+, Clave28+, Clave45+, ClaveB)

USB port:

All sterilization data from each cycle will be recorded to the USB Flash drive when it connected. Each cycle is saved as a ".txt" file that can be opened on any PC.

Internal memory :

The last 10,000 cycles are automatically stored in the autoclave system, which can be printed out at anytime.



STERILIZATION PROGRAMS

Pre-Programmed Cycles Cover all common dental, medical and veterinary sterilization needs.

Programs	Temp °C	Pressure k.Pa	Type	Total time (Mins)
Unwrapped	134	210	Unwrapped solid material	14-30
	121	110		30-45
Wrapped	134	210	Wrapped solid or hollow material	30-45
	121	110		35-60
Liquid	134	210	Liquid	30-55
Plastic	121	110	Plastic	35-60
Prion	134	210	Unwrapped porous material	Total 30-55
			Single-wrapped porous material	
			Single-wrapped hollow material	
			Dual-wrapped solid & hollow material	

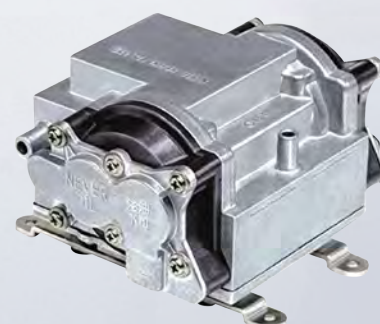

Built in compressor for
Faster Drying Times
30 Minutes Closed Door Drying

CLASS S

CLAVE28+

FULLY AUTOMATIC



FEATURES

Large 28L Chamber Capacity

Designed to accommodate a higher volume of instruments—ideal for busy dental offices needing efficient sterilization of larger loads.

LCD Control Panel

LCD interface with pre-set sterilization programs for wrapped, unwrapped, and Prion cycles.

Built-In USB Data Logger

Automatically records cycle data for easy transfer and storage—ensuring compliance with record-keeping requirements.

Durable Stainless-Steel Chamber

11" chamber autoclave to replace existing same size autoclaves without having to change cassettes.

Compact Countertop Design

Space-saving design that fits seamlessly into modern sterilization centers.

BENEFITS

Enhanced Efficiency – Sterilizes more instruments in fewer cycles, increasing productivity and reducing wait times.

User-Friendly Operation – Simple interface eliminates guesswork and training time.

Regulatory Compliance – Automatic data recording meets Health Canada and FDA documentation requirements.

Patient & Staff Safety – Multiple safety interlocks and real-time monitoring ensure safe operation.

Cost-Effective – Low maintenance design and efficient cycle times reduce overall operating costs.

Reliable Performance – Engineered and tested to meet international standards (ISO 13485, CE, ETL).

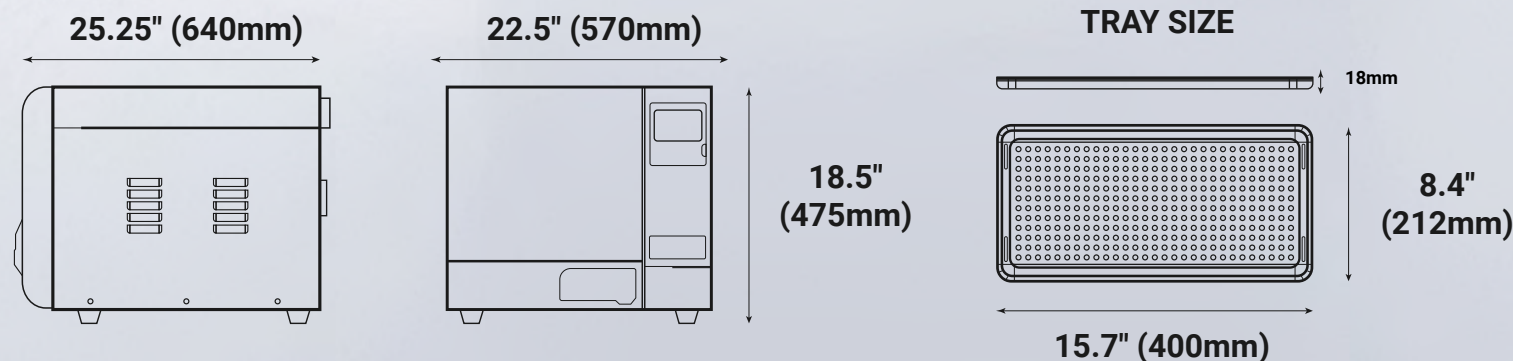

FULLY AUTOMATIC



12 Minute Cycle



Small Footprint



Big Power



Distilled Water



CLAVE 28+ TECHNICAL SPECIFICATIONS

Model	Clave 28+
Chamber (m, diameter/depth)(inches)	Ø 11" x 19" (279mm x 483mm)
Overall dimensions (mm,W*H*D)	22.5" (570mm)(W) x 18.5" (475mm) (H) x 25.25"(640mm)(D)
Net Weight (kg)	92
Nominal power (VA)	1600
Electrical supply	110V: 60Hz, 15A Breaker
Sterilization temperatures	2.5 L (Water at level Min.) Approx.
Capacity of the distilled water tank	0.5 L Approx.
Circuit breaker	15A
Operation temperature	5°C ~ 40°C
Operation relative humidity	Max. 80%, non-condensing
Max. Noise level	<70 dB
Atmospheric pressure	76 kPa ~ 106 kPa
Warranty	2 Years parts warranty

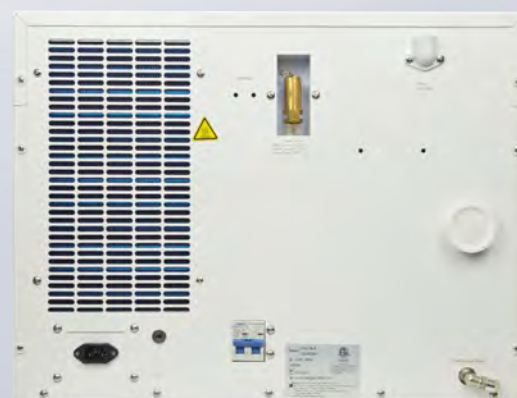

Stainless steel chamber and trays



Touchpad control



Independent steam generator

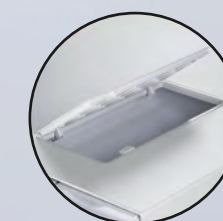

Distilled water reservoir

FULLY AUTOMATIC

CLASS S

CLAVE45+

STEAM STERILIZER 45L

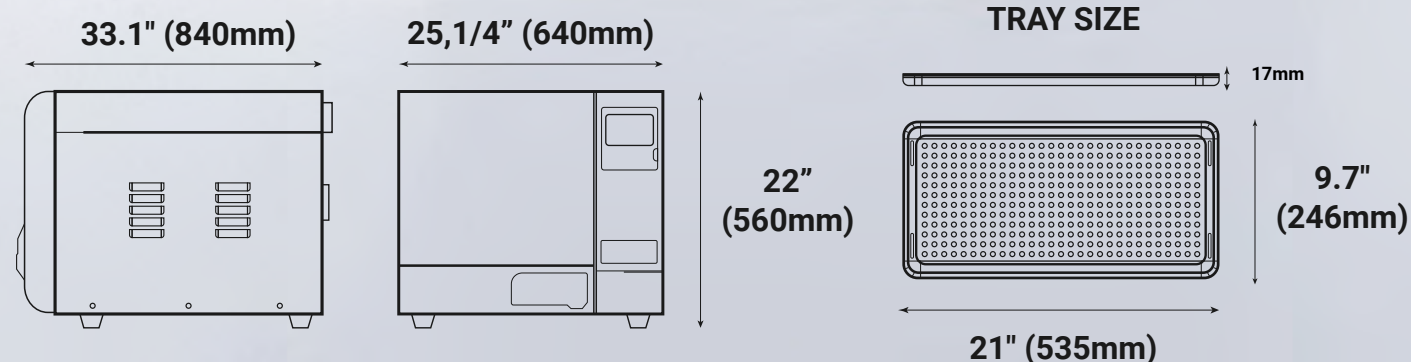

LARGE CAPACITY & EFFICIENT FOR ALL APPLICATIONS

- Easy to repair - Quality parts made in Europe
- Built in printer included
- Double door protection system - Prevents door from opening during cycle
- Closed door drying
- Electronic door closing mechanism
- After the sterilization holding phase, the chamber is evacuated by a vacuum pump to ensure faster, more effective drying
- Perfect for labs, Dental, Medical, Veterinary & Food processing facilities

STERILIZATION PROGRAMS

Pre-Programmed Cycles Cover all common dental, medical and veterinary sterilization needs

Programs	Temp °C	Pressure k.Pa	Type
Unwrapped	134	210	Unwrapped solid material
	121	110	
Wrapped	134	210	Wrapped solid or hollow material
	121	110	
Liquid	121	110	Liquid
Prion	134	210	Unwrapped porous material
			Single-wrapped porous material
			Dual-wrapped porous material
			Single-wrapped hollow material
			Dual-wrapped solid & hollow material

FULLY AUTOMATIC

TROLLEY INCLUDED WITH EACH UNIT



FLIGHT CLAVE45+

Capacity	45 L
Load size	22lbs-Wrapped
Chamber size	Ø 12.5" X 24.3" (45L)
Cycle time	70min Wrapped
Voltage	220V - 15A Breaker, 2600W Power
Internal memory	10,000 Cycles
Printer	Built in (Included)
Datalogger	USB
Warranty	2 Year Parts Warranty
Trays	2 or 5
Clean water reservoir	Internal Tank
Waste water	Internal Tank and Auto Drain
Bowie dick test	Not Required
Class of sterilizer	Class S

DIMENSION

W	25.2"
H	22"
D	33.1"
Door Open Width (WO)	29.9"
Door Open Width (HO)	49.8"

CHAMBER TYPES



FULLY AUTOMATIC

AUTOCLAVE CLASS B



CLASS B

FULLY AUTOMATIC

CLAVE B



FEATURES

Optimized tank concept, simple opening method, convenient water filling and easy cleaning.



The LCD display uses a dynamic graphical appearance that will show the whole process of sterilization, including all stages of time, temperature and pressure.

The **Clave B** is equipped with a standard USB 2.0 interface that automatically records the data of each sterilization cycle in a "TXT" file.

The last 10,000 sterilization reports will be saved on an internal memory and can be transferred to a USB drive or printed at any time.

The display shows distilled water level, waste water level, printer connected and do or locks symbols.

A specific error code is displayed to facilitate trouble shooting.



SAFETY

The Clave B is compact and clean with a unique door design that hides the printer, USB Interface, Water drain ports and power switch.

The Clave B uses both a mechanical hook type door lock and an electric door lock for added safety when a sterilization cycle is running.

The microswitch for the door locking systems ensures that the cycle cannot start if the door is not closed.

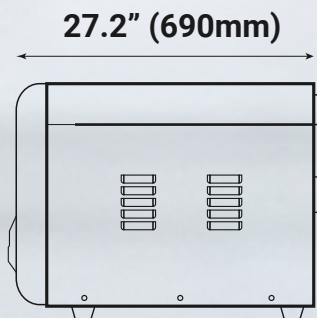

27.2" (690mm)

19.3" (490mm)

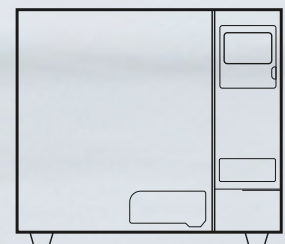

17.9" (455mm)

TRAY SIZE

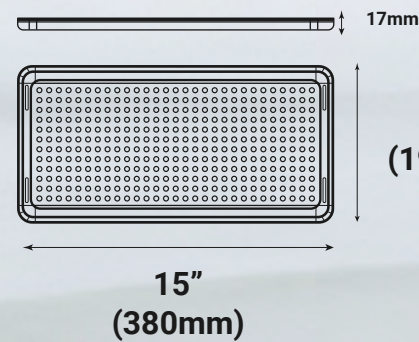

17mm

7.6" (192mm)

15" (380mm)



A high grade stainless steel chamber is used for added durability



DOCUMENTATION
Built-in printer, can automatically print the report at the end of each cycle.

CLASS B

FULLY AUTOMATIC

CLAVE B



Vacuum Pump
High quality german made vacuum pump is extremely quite. Creates optimal air removal and closed door drying for the sterilizer.



Safety Valve

The pressure release valve ensures that the pressure can be mechanically released if it over pressurizes



Steam Release Ports

A large caliber steam release port on the back of the device prevents water droplets from dripping on your counter and releasing steam unnecessarily.

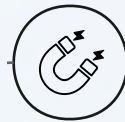

Solenoid Valve

A high quality solenoid valve from Italy provides better performance and reliability, which prevents any leakage or additional maintenance.



Heat Exchange Cooling Vent

The heat exchange and cooling fan, cools the steam prior to reaching the waste water reservoir and exhaust vent, so that minimal hot air and moisture is exhausted out.



Bacterial Filter

Premium bacteria filter increases filtration efficiency and reduces maintenance required.

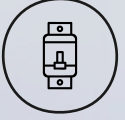

Circuit Breaker

UL approved circuit breaker automatically trips when the current is not stable or there is a short circuit to prevent damage to the device.



FLIGHT ULTRASONIC CLEANER



Simple to Operate

The Flight SonicArc is easy to use right out of the box, so you can get your staff up and running with minimal training time. Features like a digital LCD control panel that displays prompts, options for preset or customized settings, intelligent software that remembers the last cycle settings, and a fluid sensor that ensures the bath always has sufficient water levels help simplify your processes and increase productivity.

- LCD Digital Display
- Multi-function Integration
- High-Precision Temp Control
- Dynamic Light Bar

SAFETY

Optimize your cleaning process with the Flight Ultrasonic Cleaner, available in four convenient sizes: 3.2L, 6.5L, 10L, and 22L. Designed for dental, medical, veterinary, laboratory, industrial, tattoo, and eyewear applications, this intelligent cleaner features an LCD digital display, high-precision temperature control, and a dynamic light bar for simple operation. Its ultra-powerful ultrasonic technology ensures thorough cleaning while minimizing worker exposure to contaminants and sharps. With a sleek, modern design and advanced functionality, the Flight Ultrasonic Cleaner is a smart, safe, and stylish addition to any workspace.

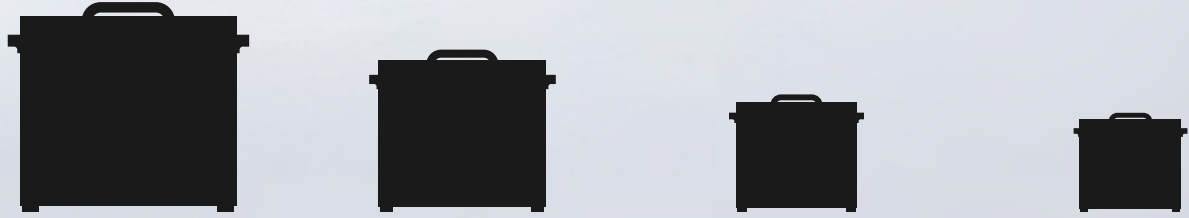

Range of sizes and design options

The SonicArc comes in four table top sizes (3.2L, 6.5L, 10L, 22L), So you choose the option that best fits your configuration and workflow. And the stainless steel finish and attractive design coordinate well with any decor.



ACCESSORIES AND SERVICE PARTS



Feature / Model	UC-6032	UC-6065	UC-6100	UC-6220
Tank Capacity gal/L	0.85Gal/3.2L	1.7Gal/6.5L	2.64Gal/10L	5.8Gal/22L
Ultrasonic Frequency	40 kHz	40 kHz	40 kHz	40 kHz
Heater Option	Yes	Yes	Yes	Yes
Timer Control	Yes	Yes	Yes	Yes
Drainage Valve	No	Yes	Yes	Yes
Warranty	1 Year	1 Year	1 Year	1 Year
Heating Power	200W	300W	400W	600W
Ultrasonic Power	120/60W	180/90W	240/120W	480/240W
Tank Size Dimensions (W x D x H)	9.5 x 5.3 x 3.9"	11.8 x 5.9 x 5.9"	11.8 x 11.4 x 11"	19.7 x 11.8 x 5.9"
Product Size (W x D x H)	10.6 x 7.3 x 9"	14.8 x 7.9 x 10.8"	15 x 11.4 x 11"	23 x 13 x 11"
Weight	7.9lbs (3.6kg)	14.1lbs (6.4kg)	16.8lbs (7.6kg)	29.3(13.3kg)
Noise Level	<60db	<60db	<60db	<60db

AUTOCLAVE ACCESSORIES

The Flight sterilization cassettes are made with high quality stainless steel material and silicone racks to prolong the life of the product after continuous processing and sterilization. The flight cassettes come in 5, 10, 15 and 20 instrument cassettes.

Features

- Premium stainless steel cassettes.
- Silicone racks.
- Optional syringe clips and instrument clips.
- Easy locking mechanism.
- Two separate parts - Top lid and bottom tray.

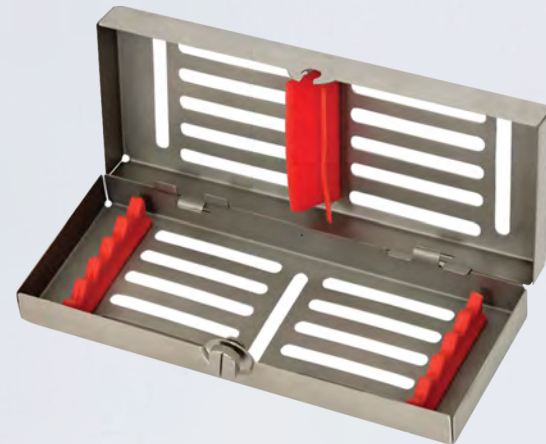

5

5 Instrument Capacity
Order No. CA-5001

Dimensions:
1-5/16" x 3" x 7-1/4"
(33.3 x 76.2mm x 184.2mm)

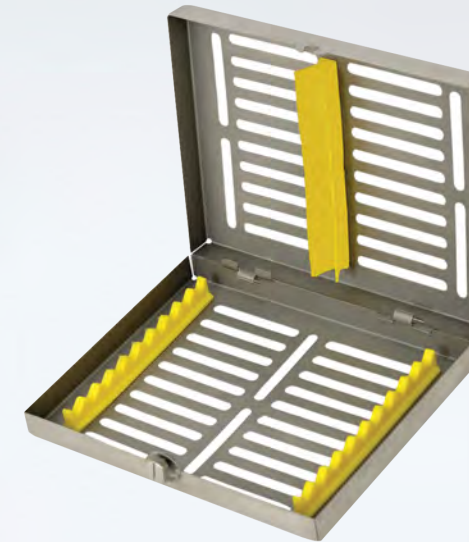

10

10 Instrument Capacity
Order No. CA-1001

Dimensions:
1-3/8" x 5-11/16" x 7-1/4"
(34.9mm x 144.5mm x 184.2mm)



15

15 Instrument Capacity
Order No. CA-1501

Dimensions:
1-3/8" x 7-1/4" x 8-1/2"
(34.9mm x 184.2mm x 215.9mm)

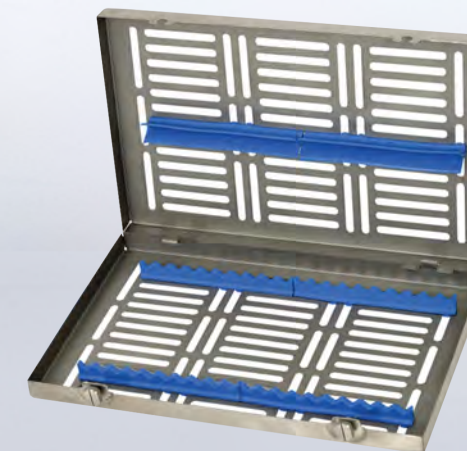

20

20 Instrument Capacity
Order No. CA-2001

Dimensions:
1-5 / 16" x 7-5/16" x 11-7/16"
(33.3mm x 185.7mm x 290.5mm)

TECHNICAL SPECIFICATIONS

Model	Chamber Dimensions (Diameter x L in (mm))	Vol	Overall Dimensions DxWxH in (mm)	Tray Dimensions DxWxH in (mm)	No. of Trays	Voltage (V) Freq. (Hz)	Power (VA)	Shipping Weight lbs (kg)
Clave8+	6.7" x 12.6" (170mm x 320mm)	8 L	D 20.7" x W 16.5" x H 14.6" (D 525mm x W 420mm x H 370mm)	D 10.4" x W 5.1" x H 0.7" (D 130mm x W 265mm x H 18mm)	3	110 V - 60Hz	1600VA	82 lbs (37kg)
Clave16+	9.05" x 14.17" (230mm x 360mm)	16 L	D 23.6" x W 19.3" x H 17.9" (D 600mm x W 490mm x H 455mm)	D 11.2" x W 6.7" x H 0.7" (D 285mm x W 170mm x H 18mm)	3	110 V - 60Hz	1600V A	92 lbs (42kg)
Clave23+	9.72" x 17.71" (247mm x 450mm)	23 L	D 27.2" x W 19.3" x H 17.9" (D 690mm x W 490mm x H 455mm)	D 15" x W 7.6" x H 0.7" (D 380mm x W 192mm x H 18mm)	4	110 V - 60Hz	1600V A	121lbs (55kg)
Clave28+	11" x 19" (279mm x 483mm)	28 L	D 25.25" x W 22.5" x H 18.5" (D 640mm x W 570mm x H 475mm)	D 15.7" x W 8.4" x H 0.7" (D 400mm x W 212mm x H 18mm)	4	110 V - 60Hz	1600V A	202 lbs (92kg)
Clave45+	12.6" x 24.3 (319mm x 617mm)	45 L	D 33.1" x W 25.2" x H 22.0" (D 840mm x W 640mm x H 560mm)	D 21" x W 9.7" x H 0.7" (D 535mm x W 246mm x H 17mm)	2 or 5	220V - 60Hz	2300V A	227 lbs (103kg)
ClaveB	9.72" x 17.71" (247mm x 450mm)	23 L	D 27.2" x W 19.3" x H 17,9" (D 690mm x W 490mm x H 455mm)	D 15" x W 7.6" x H 0.7" (D 380mm x W 192mm x H 18mm)	4	230 V - 60Hz	2300VA	141 lbs (64kg)

FULLY AUTOMATIC STERILIZER

Ultra Fast Class S



Clave8+

Class S Automatic Sterilizer



Clave16+



Clave23+



Clave28+



Clave45+

Class B Pre/Post Vacuum Sterilizer



ClaveB

Health Canda Licensed
ETL/CSA Approved Mark
ISO 13485:2016
FDA Approved

Flight Dental Systems Canada
21 Kenview Blvd., Unit 9,
Brampton, ON, L6T 5G7,
CANADA

Flight Dental Systems USA Inc.
3103 Farrell Road, Houston,
Texas, 77073, USA

Phone: 905-799-0517
Toll Free: 1-866-799-0517
Fax: 1-905-793-2406



www.flightdentalsystems.com

Distributed by: